

FLEXEO - D

SEMI-AUTOMATIC DRUM FILLER

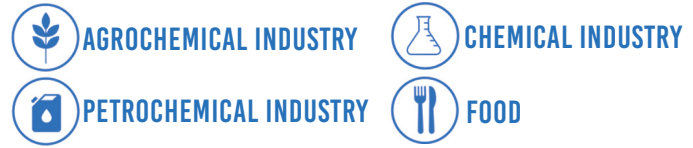

CLEAN & ACCURATE FILLING

- > Weight-filling system
- > Weighing accuracy not affected by temperature variation
- > Minimum product give-away with very high accuracy
- > Drip cup
- > Fume exhaust hood (transparent and height adjustable)

INTUITIVE INTERFACE

- > User friendly, easy to use
- > Traceability
- > Programmable recipes
- > Maintenance assistance

FLEXIBLE EQUIPMENT

- > Adjustable height to allow multi-format
- > Interchangeable filling lance
- > No tools needed
- > Several filling lances :
 - Viscous
 - Foamy
 - Corrosive
- > Several filling position :
 - Sub-surface
 - Above product
 - Below bung-hole



CONTAINERS > OUTPUTS

20L-60L > 70 - 120 CPH
200L drum > 40 drums/h

CAPS

Screw cap and crimping capsule



Explosion proof design and corrosive products

CONTACT US

www.packr.com

PACK'R EUROPE

✉ sales@packr.com

☎ +33 (0)2 41 73 29 73

PACK'R USA

✉ sales.usa@packr.com

☎ +1 770 904 6500

PACK'R ASIA

✉ sales.asia@packr.com

☎ +65 6752 4840

+ ADVANTAGES

- > Ergonomic and compact design
- > Permanent spare part stock
- > Many options and additional equipment available

OPTIONS

- > Crimping / bunging
- > Conveyor systems and controls
- > Quick and easy Cleaning in Collector
- > Legal metrology

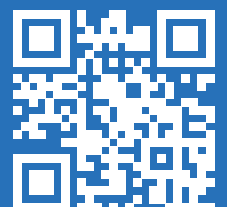

WORKING PRINCIPLE

1 Select production settings

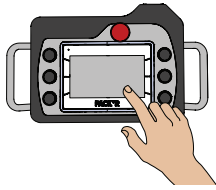

- > Product
- > Container

2 Operator's manual operations before filling

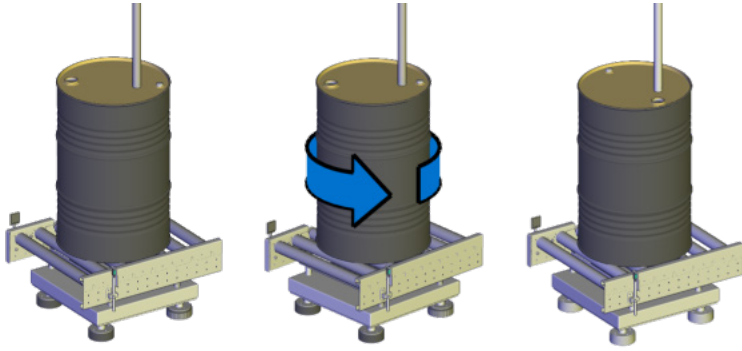

3 Filling according to 3 modes

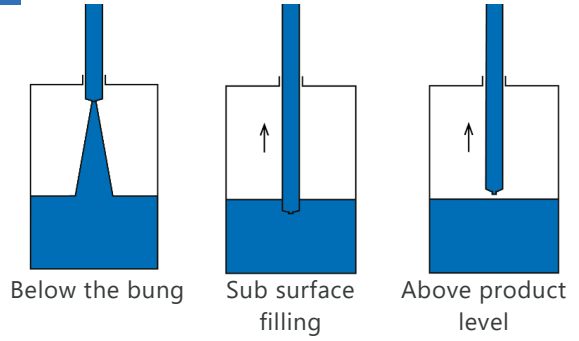

4 End of filling

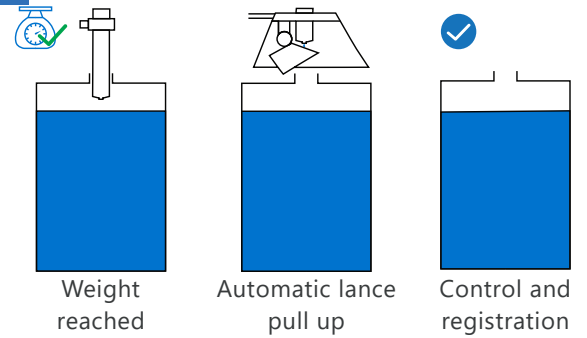

DIMENSIONS (mm & inch)

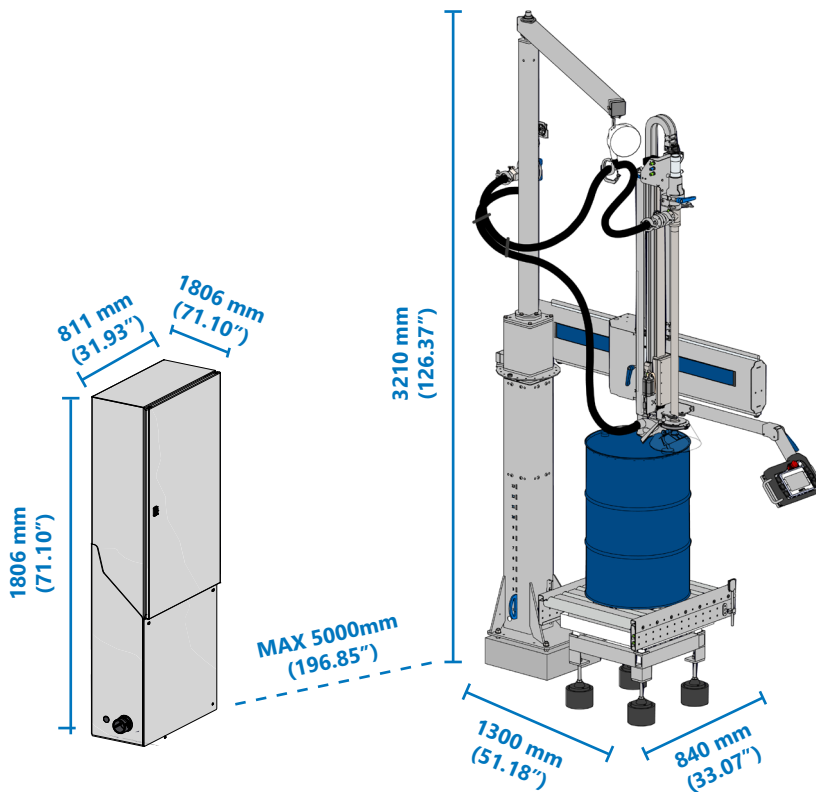

TECHNICAL DATA

Electric design : 110 - 230V 50 - 60 Hz
Air consumption : 10 Nm³
Machine Frame : Stainless steel
Conveyors : Gravity or motorized rollers

Balance maximum capacity : 2000 kg
Interface : 7" touchscreen color
Product supply connection : 2"
Product pressure : Up to 10 Bars